

The Soaring Eagle

Steps 1-6

Note: This paper airplane uses a ruler and measurements!

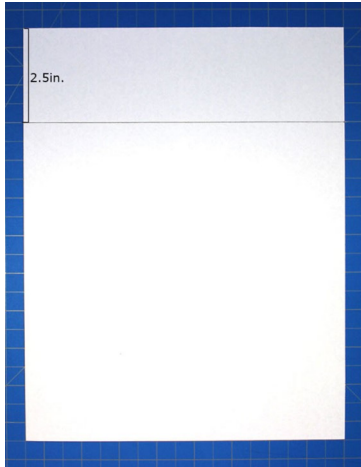
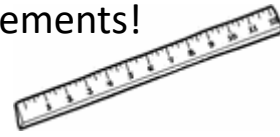

1. Measure 2.5 inches down from the top corners and draw a line.

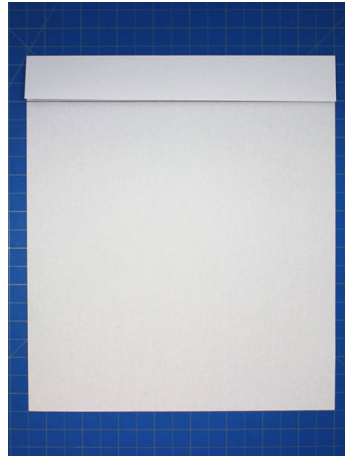

2. Fold the top edge at the line.

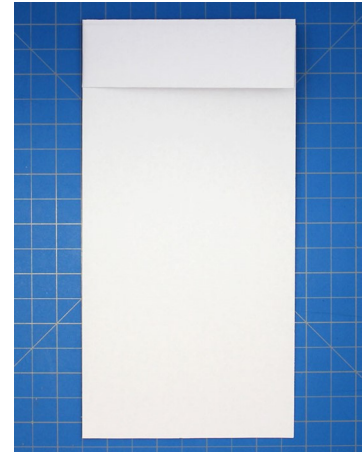

3. Next, fold the plane in half, like a hotdog, with the flaps on the outside.



4. Fold the top right corner down along the opposite edge.

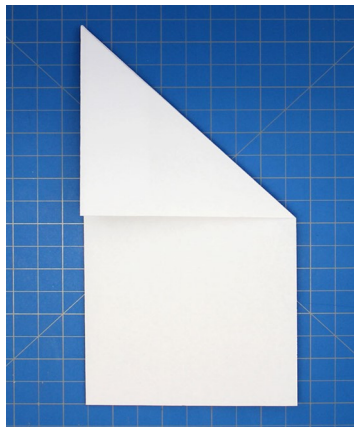

5. Flip the plane around and repeat with the other side.



6. Flatten out the sheet of paper, like in step two, and refold the top corners so they meet the diagonal creases.

Steps 7-15 continue on the next page

The Soaring Eagle Steps 7-15



7. Then, refold along the crease.



8. Fold the top peak down to the



9. Fold the peak back up as shown.



10. Fold the top outer edges along each side of the triangle shape.

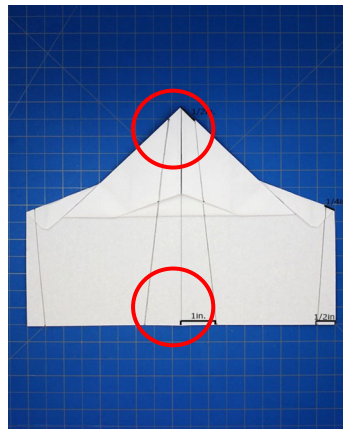

11. Mark .5 in from the peak on each side, and 1 in from the center fold on the bottom on each side. Connect the marks.

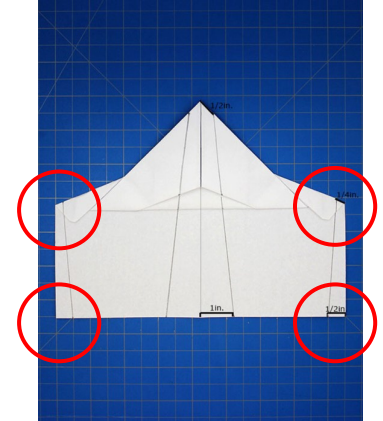

12. Mark .25 in from each upper corner and .5 in from each bottom corner. Connect the marks.



13. Now, fold the plane in half and fold the wings down along the inner-most lines.



14. Fold the wing tips up along the outer-most lines.



15. Tape or glue the nose of the plane together.